

UNITED STATES PATENT AND TRADEMARK OFFICE

---

BEFORE THE PATENT TRIAL AND APPEAL BOARD

---

EMC CORPORATION AND VMWARE, INC.  
Petitioner

v.

PERSONALWEB TECHNOLOGIES LLC  
Patent Owner

---

Case IPR2013-00083 (JYC)  
U.S. Patent No. 6,415,280

---

Before KEVIN F. TURNER, JONI Y. CHANG, and  
MICHAEL R. ZECHER, *Administrative Patent Judges*.

ZECHER, *Administrative Patent Judge*.

DECISION  
Institution of *Inter Partes* Review  
37 C.F.R. § 42.108

## I. INTRODUCTION

EMC Corporation and VMware, Inc. (“EMC”) filed a petition (“Pet.”) requesting *inter partes* review of claims 36 and 38 of U.S. Patent No. 6,415,280 (“the ’280 patent”). Paper No. 6. Patent owner, PersonalWeb Technologies LLC (“PersonalWeb”), filed a preliminary response (“Prelim. Resp.”). Paper No. 14. We have jurisdiction under 35 U.S.C. § 314.

The standard for instituting an *inter partes* review is set forth in 35 U.S.C. § 314(a), which provides:

**THRESHOLD** --The Director may not authorize an *inter partes* review to be instituted unless the Director determines that the information presented in the petition filed under section 311 and any response filed under section 313 shows that there is a reasonable likelihood that the petitioner would prevail with respect to at least 1 of the claims challenged in the petition.

Taking into account PersonalWeb’s Preliminary Response, we conclude that the information presented in the Petition demonstrates that there is a reasonable likelihood that EMC will prevail in challenging claims 36 and 38 as unpatentable under 35 U.S.C. §§ 102 and 103. Pursuant to 35 U.S.C. § 314, we hereby authorize an *inter partes* review to be instituted as to claims 36 and 38 of the ’280 patent.

### A. *Related Matters*

EMC indicates that the ’280 patent was asserted against it in *PersonalWeb Technologies LLC v. EMC Corporation and VMware, Inc.*, Case No. 6:11-cv-00660-LED, pending in the U.S. District Court for the Eastern District of Texas. Pet. 1. EMC also filed five other Petitions

Case IPR2013-00083  
U.S. Patent No. 6,415,280

seeking *inter partes* review of the following patents: U.S. Patent No. 5,978,791 (IPR2013-00082), U.S. Patent No. 7,945,544 (IPR2013-00084), U.S. Patent No. 7,945,539 (IPR2013-00085), U.S. Patent No. 7,949,662 (IPR2013-00086), and U.S. Patent No. 8,001,096 (IPR2013-00087). *Id.* According to EMC, those patents and the '280 patent share a common disclosure. *Id.* (citing to Ex. 1008).

*B. The Invention of the '280 Patent (Ex. 1001)*

The invention of the '280 patent relates to a data processing system that identifies data items using substantially unique identifiers, otherwise referred to as True Names, which depend on all the data in the data item and only on the data in the data item. Ex. 1001, Spec. 1:12-16, 3:28-31, and 6:7-9. According to the '280 patent, the identity of a data item depends only on the data and is independent of the data item's name, origin, location, address, or other information not directly derivable from the data associated therewith. Ex. 1001, Spec. 3:32-34. The invention of the '280 patent also examines the identities of a plurality of data items in order to determine whether a particular data item is present in the data processing system. Ex. 1001, Spec. 3:35-38.

Figures 1(a) and 1(b) illustrate the data processing system that implements the invention of the '280 patent. Ex. 1001, Spec. 4:45-47. Figure 1(a) is reproduced below.

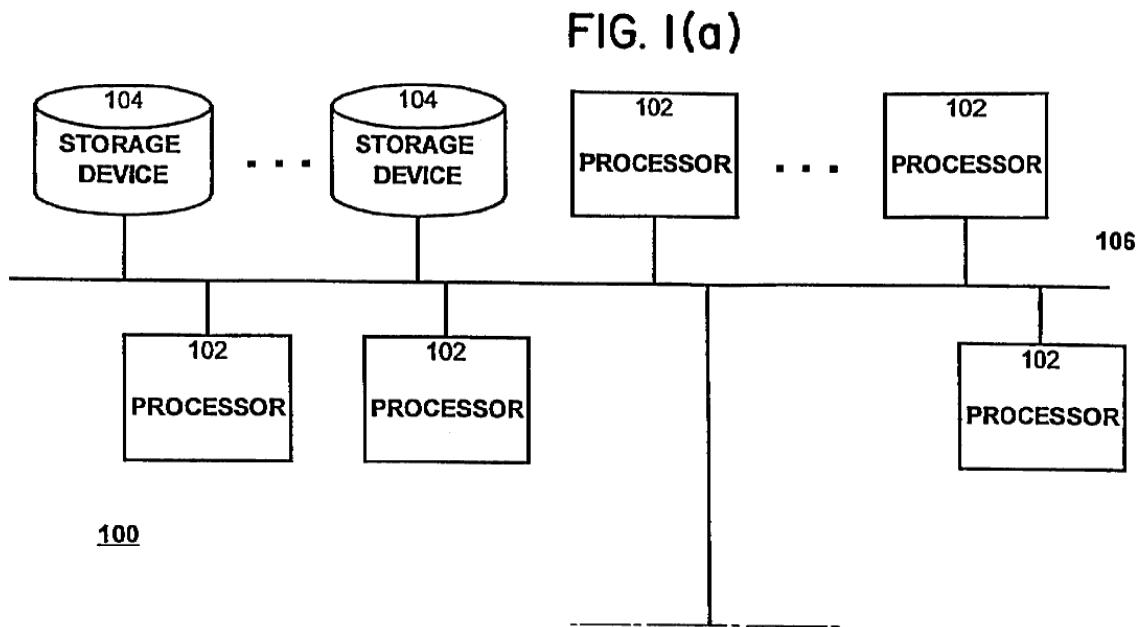

**Figure 1(a) illustrates the data processing system 100.**

The Specification of the '280 patent discloses that the data processing system 100 includes one or more processors 102 and various storage devices 104 connected via bus 106. Ex. 1001, Spec 4:59-64.

Figure 1(b) is reproduced below.

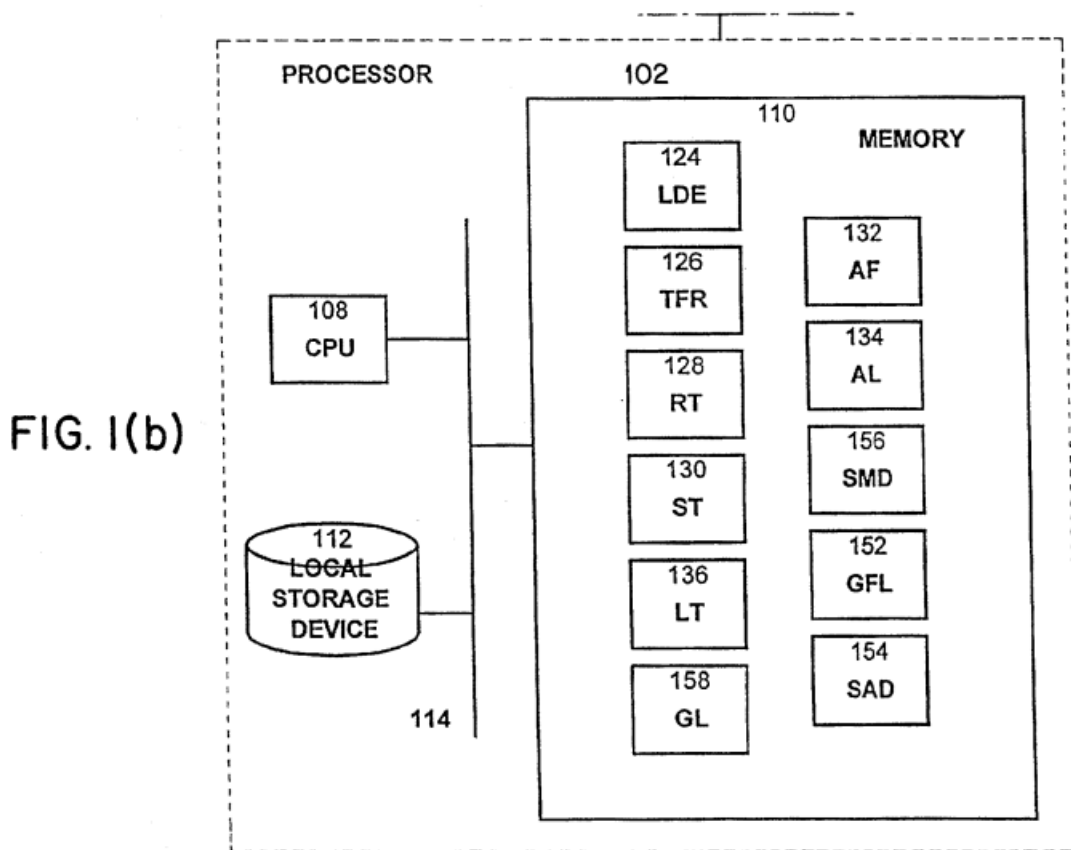

**Figure 1(b) illustrates a typical data processor 102 in the data processing system 100.**

The Specification of the '280 patent discloses that each processor 102 includes a central processing unit 108, memory 110, and one or more local storage devices 112 connected via an internal bus 114. Ex. 1001, Spec. 4:65-5:1. The memory 110 in each processor 102 stores data structures that are either local to the processor itself or shared amongst multiple processors in the data processing system. Ex. 1001, Spec. 7:65-8:13.

The Specification of the '280 patent further discloses accessing data items by referencing their identities or True Names independent of their present location in the data processing system. Ex. 1001, Spec. 34:21-23. The actual data item or True file corresponding to a given data identifier or True Name is capable of residing anywhere on the data processing system, *i.e.*, locally, remotely, offline, etc. Ex. 1001, Spec. 34:23-25. If a requested data item or True File is local with respect to the data processing system, a prospective user can access the data in the True File. Ex. 1001, Spec. 34:25-27. If a requested data item or True File is not local with respect to the data processing system, a prospective user may use the True File registry to determine the location of copies of the True File according to its given True Name. Ex. 1001, Spec. 34:27-31. However, if for some reason a prospective user cannot locate a copy of the requested data item or True File, the processor employed by the user may invoke the Request True File remote mechanism to submit a general request for the data item or True File to all the processors in the data processing system. Ex. 1001, Spec. 34:35-41.

### *C. Challenged Claims*

Independent claims 36 and 38 are the only claims challenged by EMC in this *inter partes* review and are reproduced below:

36. A method of delivering a data file in a network comprising a plurality of processors, some of the processors being servers and some of the processors being clients, the method comprising:

storing the data file is [sic] on a first server in the network and storing copies of the data file on a set of servers in the network distinct from the first server; and  
responsive to a client request for the data file, the request including a hash of the contents of the data file, causing the data file to be provided to the client.

Ex. 1001, claims—Spec. 43:54-63.

38. A method of delivering a data file in a network comprising a plurality of processors, some of the processors being servers and some of the processors being clients, the method comprising:  
storing the data file is [sic] on a first server and storing copies of the data file on a set of servers distinct from the first server; and  
responsive to a client request for the data file, the request including a value determined as a given function of the contents of the data file, providing the data file to the client.

Ex. 1001, claims—Spec. 44:3-13.

*D. Prior Art Relied Upon*

EMC relies upon the following prior art references:

Woodhill      US 5,649,196      July 15, 1997      Ex. 1005

Shirley Browne et al., “*Location-Independent Naming for Virtual Distributed Software Repositories*,” University of Tennessee Technical Report CS-95-278 (Feb. 1995)(Ex. 1002)(hereinafter “Browne”).

Albert Langer, “*Re: dl/describe (File descriptions)*,” post to the “alt.sources” newsgroup on Aug. 7, 1991 (Ex. 1003)(hereinafter “Langer”).

Frederick W. Kantor, “*FWKCS(TM) Contents\_Signature System Version 1.22*,” Zipfile FWKCS122.ZIP (Aug. 10, 1993)(Ex. 1004)(hereinafter “Kantor”).

“*ESM™ : Product Introduction*,” Document No. ES-LAN22-1, Legent Corp. (April 1994)(Ex. 1026)(hereinafter “ESM Manual”).

Mahadev Satyanarayanan, “*Scalable, Secure, and Highly Available Distributed File Access*,” 23 IEEE Computer 9-21 (May 1990)(Ex. 1029)(hereinafter “Satyanarayanan”).

#### *E. Alleged Grounds of Unpatentability*

EMC seeks to cancel independent claims 36 and 38 of the '280 patent based on the following alleged grounds of unpatentability:

1. Claims 36 and 38 as anticipated under 35 U.S.C. § 102(a) by Browne. Pet. 28-38.
2. Claims 36 and 38 as unpatentable under 35 U.S.C. § 103(a) over the combination of Browne and Langer. *Id.* at 38-39.
3. Claims 36 and 38 as anticipated under 35 U.S.C. § 102(e) by Woodhill. *Id.* at 39-47.
4. Claims 36 and 38 as unpatentable under 35 U.S.C. § 103(a) over Woodhill. *Id.* at 47-48.
5. Claims 36 and 38 as anticipated under U.S.C. § 102(b) by ESM Manual. *Id.* at 48-51.
6. Claims 36 and 38 as unpatentable under 35 U.S.C. § 103(a) over the combination of Satyanarayanan and Langer. *Id.* at 51-56.
7. Claims 36 and 38 as unpatentable under 35 U.S.C. § 103(a) over the combination of Satyanarayanan and Kantor. *Id.* at 56-59.



## II. CLAIM CONSTRUCTION

During an *inter partes* review, the Board construes claims by applying the broadest reasonable interpretation in light of the specification. 37 C.F.R. § 42.100(b); *see also* Office Patent Trial Practice Guide, 77 *Fed. Reg.* 48756, 48766 (Aug. 14, 2012). Absent a special definition for a claim term being set forth in the specification, the definition that governs is the ordinary and customary meaning of the claim term as would be understood by one with ordinary skill in the art. *Phillips v. AWH Corp.*, 415 F.3d 1303, 1312 (Fed. Cir. 2005) (en banc). In some cases, the ordinary and customary meaning of a claim term as would be understood by one with ordinary skill in the art may be apparent even to lay judges, and claim construction in such cases involves little more than the application of the widely accepted meaning of commonly understood words. *Id.* at 1314.

### A. Preambles

In general, a preamble is construed as a limitation “if it recites essential structure or steps, or if it is ‘necessary to give life, meaning, and vitality’ to the claim.” *Catalina Mktg. Int’l, Inc. v. Coolsavings.com, Inc.*, 289 F.3d 801, 808 (Fed. Cir. 2002) (quoting *Pitney Bowes, Inc. v. Hewlett-Packard Co.*, 182 F.3d 1298, 1305 (Fed. Cir. 1999)). In this case, the preambles of independent claims 36 and 38 both recite “[a] method of delivering a data file in a network comprising a plurality of processors, some of the processors being servers and some of the processors being clients.” Further, the bodies of independent claims 36 and 38 both include similar

language—namely “a first server in the network,” “a set of servers in the network distinct from the first server,” and “a client.” We hold that the bodies of independent claims 36 and 38 depend on their preambles for completeness. Accordingly, we conclude that the preambles of these claims are entitled to patentable weight.

### *B. Claims Terms*

EMC identifies six claim terms and its claim construction for each claim term. Pet. 6-7. Those claim terms are listed as follows: (1) “data” and “data item;” (2) “file system;” (3) “file;” (4) “location;” (5) “local;” and (6) “True Name, data identity, and data identifier.” *Id.* However, only the claim terms “data” and “file” are used together as “data file” in independent claims 36 and 38. We will address the claim term “data file” below.

#### *1. “Data file”*

EMC construes the claim term “file” as:

a named data item which is either a data file (which may be simple or compound) or a directory file. A simple file consists of a [single] data segment. A compound file consists of a sequence of data segments. A data segment is a fixed sequence of bytes.

*Id.* at 7 (citing to Ex. 1001, Spec. 5:47-54). In response, PersonalWeb construes the claim term “data file” as “a named data item that appears in a directory and which is a data file (which may be simple or compound).” Prelim. Resp. 3-4 (citing to Ex. 1001, Spec. 5:46-50). PersonalWeb further contends that EMC’s proposed claim construction is for the claim term “file” instead of the claim term “data file.” *Id.* at 4. PersonalWeb argues that the

Board should construe the claim term “data file” in accordance with PersonalWeb’s proposed claim construction because these two claim terms, *i.e.*, “data” and “file,” are used together in independent claims 36 and 38. *Id.*

The portion of the Specification of the ’280 patent cited by both EMC and PersonalWeb sets forth an explicit or special definition for the claim term “file.” Because that explicit or special definition indicates that “[a] file is . . . a data file,” we construe the claim term “data file” as a named data item, such as a simple file that includes a single, fixed sequence of data bytes or a compound file that includes multiple, fixed sequences of data bytes.

## 2. *Remaining Claim Terms*

All remaining claim terms recited in independent claim 36 and 38 are given their ordinary and customary meaning as would be understood by one with ordinary skill in the art, and need not be further construed at this time.

## III. ANALYSIS

### A. *35 U.S.C. § 102(e) Ground of Unpatentability—Woodhill Claims 36 and 38*

EMC contends that independent claims 36 and 38 are anticipated under 35 U.S.C. § 102(e) by Woodhill. Pet. 39-47. EMC relies upon the Declaration of Dr. Douglas W. Clark (Ex. 1009) to support its positions and an attached claim chart (Ex. 1032) to explain where Woodhill describes the claimed subject matter recited in independent claims 36 and 38. *Id.* at 44-46. PersonalWeb does not challenge EMC’s assertion that Woodhill

describes the claimed subject matter recited in independent claims 36 and 38.

Woodhill generally relates to a system and method for distributed storage management on a networked computer system that includes a remote backup file server in communication with one or more local area networks. Ex. 1005, Spec. 1:11-17. Figure 1 of Woodhill illustrates the networked computer system. Ex. 1005, Spec. 2:56-58. Figure 1 of Woodhill is reproduced below.

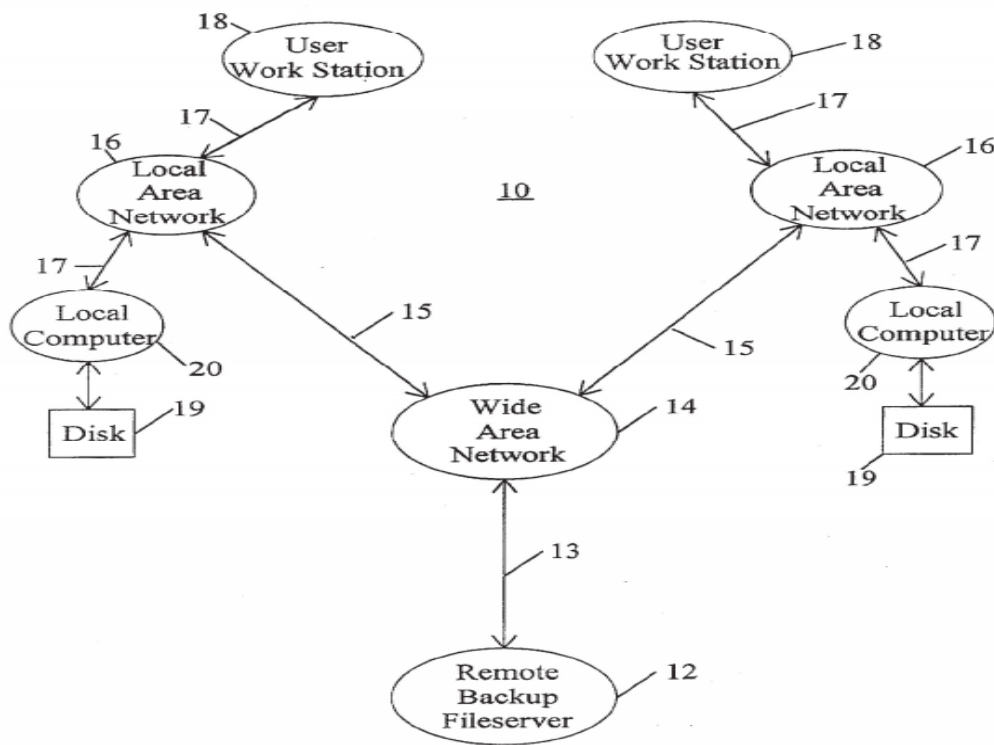

FIG. 1

Figure 1 of Woodhill illustrates the networked computer system 10.

A remote backup file server 12 communicates with a wide area network 14 via data path 13, the wide area network 14 communications with a plurality of local area networks 16 via data paths 15, and each local area network 16 communications with multiple user workstations 18 and local computers 20 via data paths 17. Ex. 1005, Spec. 3:12-30. The storage space on each disk drive 19 on each local computer 20 is allocated according the hierarchy illustrated in Figure 2. Ex. 1005, Spec. 3:31-44.

Figure 2 of Woodhill illustrates a Distributed Storage Manager program that allocates storage space on each of the storage devices in the networked computer system. Ex. 1005, Spec. 2:59-62. Figure 2 of Woodhill is reproduced below.

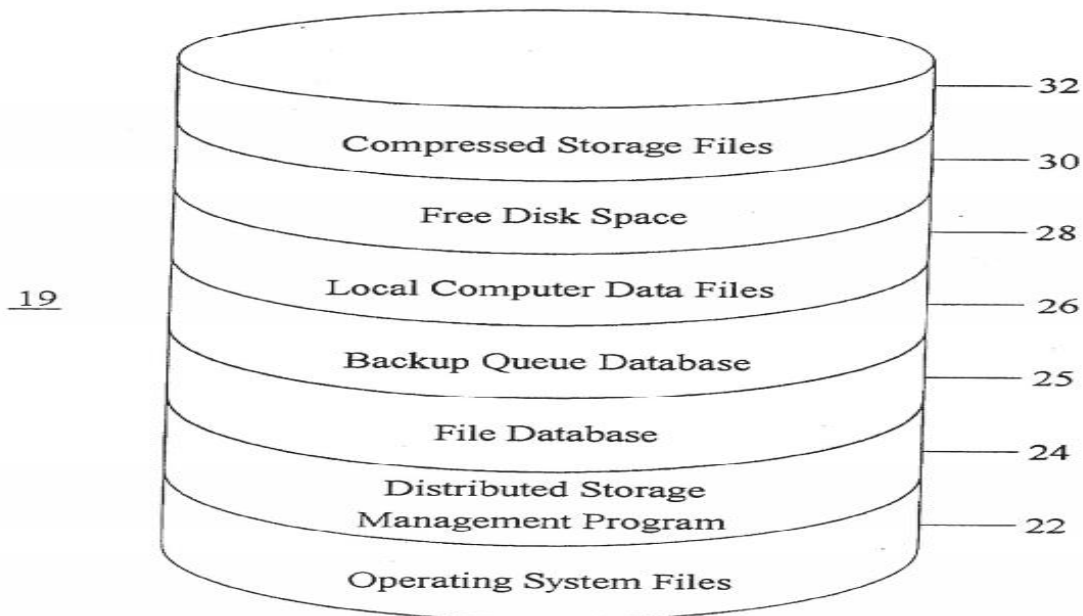

FIG. 2

**Figure 2 of Woodhill illustrates the  
Distributed Storage Manager program 24.**

The Distributed Storage Manager program 24 builds and maintains the File Database 25 on the one or more disk drives 19 on each local computer 20 in the networked computer system 10. Ex. 1005, Spec. 3:45-49. The Distributed Storage Manager program 24 views a file as a collection of data streams. Ex. 1005, Spec. 4:13-15. Woodhill defines a data stream as a distinct collection of data within a file that may change independently from other distinct collections of data within the file. Ex. 1005, Spec. 4:15-18. Depending on the size of the data stream, the Distributed Storage Manager program 24 divides each data stream into one or more binary objects. Ex. 1005, Spec. 4:21-30.

Figure 3 of Woodhill illustrates the File Database used by the Distributed Storage Manager program. Ex. 1005, Spec. 2:63-64. Figure 3 of Woodhill is reproduced below.

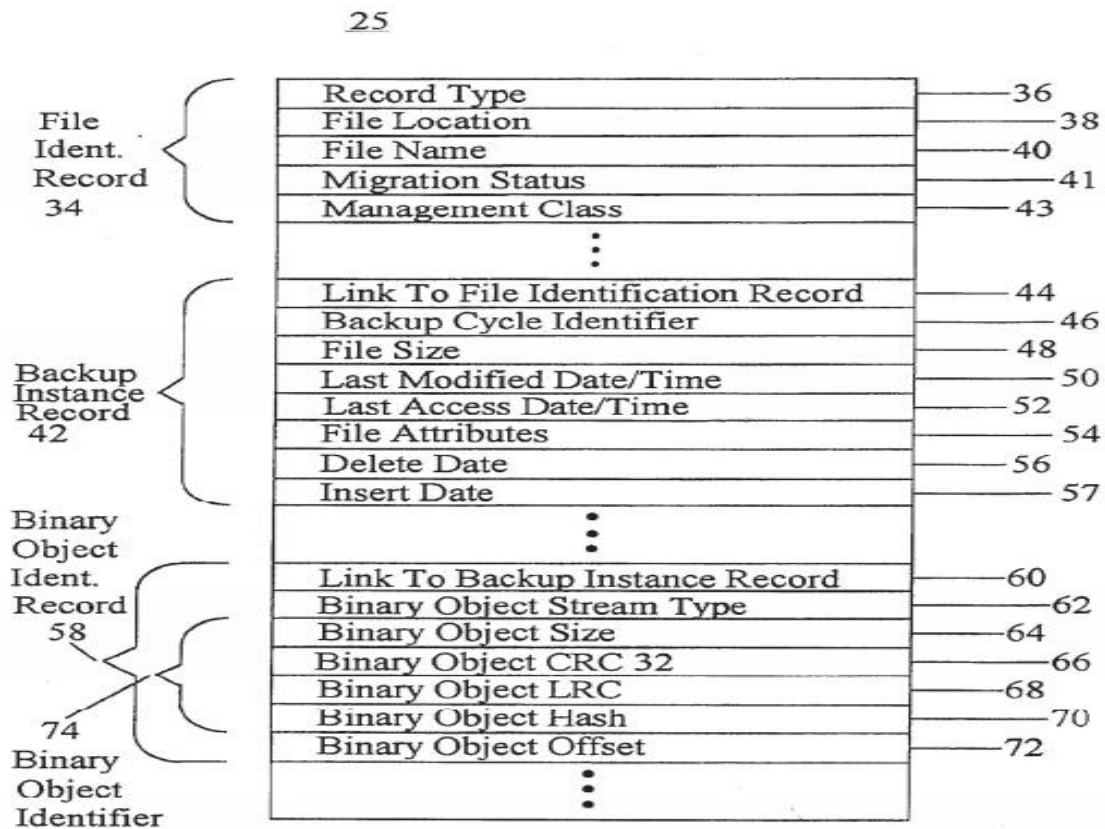

FIG. 3

Figure 3 of Woodhill illustrates the File Database 25.

The File Database 25 includes three levels of records organized according to a predefined hierarchy: (1) the File Identification Record 34; (2) the Backup Instance Record 42; and (3) the Binary Object Identification Record 58. Ex. 1005, Spec. 3:54-4:47. The Binary Object Identification Record 58 includes, amongst other things, a Binary Object Identifier 74 that comprises a Binary Object Size 64, Binary Object CRC32 66, Binary Object LRC 68 and Binary Object Hash 70. Ex. 1005, Spec. 4:45-47, 7:64-8:1. The Binary

Object Identifier 74 is a unique identifier for each binary object that is backed up. Ex. 1005, Spec. 4:45-47.

While Woodhill discloses calculating the Binary Object Identifier 74 in various ways, *e.g.*, based on a Binary Hash algorithm (Ex.1005, Spec. 8:1-31), the key notion is that the Binary Object Identifier 74 is calculated from the content of the data instead of from an external or arbitrary source. Ex. 1005, Spec. 8:38-42. In other words, Woodhill recognizes that the critical feature in creating a Binary Object Identifier 74 is that the identifier should be based on the contents of the binary object such that the Binary Object Identifier 74 can change when the contents of the binary object change. Ex. 1005, Spec. 8:58-62.

Woodhill further discloses that the Distributed Storage Manager program 24 performs two backup operations concurrently. Ex. 1005, Spec. 9:30-31. First, the Distributed Storage Manager program 24 stores a compressed copy of each binary object it needs to restore the disk drives 19 on each local computer 20 somewhere on the local area network 16 other than on the local computer 20 where the binary object originally resided. Ex. 1005, Spec. 9:31-36. Second, the Distributed Storage Manager program 24 transmits new or changed binary objects to the remote backup file server 12. Ex. 1005, Spec. 9:36-38. These concurrent backup operations enable the binary objects that are available in compressed form on the local area network 16 to be restored quickly. Ex. 1005, Spec. 9:39-40. These concurrent backup operations also ensure that at least one copy of every



binary object is stored on the remote backup file server 12. Ex. 1005, Spec. 9:40-44.

Woodhill further discloses that the Distributed Storage Manager program 24 performs auditing and reporting functions on a periodic basis in order to ensure that the binary objects, which already have been backed up, may be restored. Ex. 1005, Spec. 18:11-13. According to Woodhill, the Distributed Storage Manager program 24 initiates a restore of a randomly selected binary object identified by a Binary Object Identification Record 58 stored in the File Database 25. Ex. 1005, Spec. 18:16-19. The control aspect of the Distributed Storage Manager program 24 restores the randomly selected binary object using a compressed storage file 32 residing on one or more disk drives 19 of one of the local computers 20 or the remote backup file server 12. Ex. 1005, Spec. 18:19-23.

The explanations provided by EMC with respect to how Woodhill describes the claimed subject matter recited in independent claims 36 and 38 have merit and are otherwise un rebutted. Therefore, based on the record before us, we conclude that there is a reasonable likelihood that EMC will prevail on its assertion that independent claims 36 and 38 of the '280 patent are anticipated by Woodhill. We authorize an *inter partes* review on this ground of unpatentability.

*35 U.S.C. § 103(a) Grounds of Unpatentability—Woodhill  
Claims 36 and 39*

EMC contends that independent claims 36 and 38 are unpatentable under 35 U.S.C. § 103(a) over Woodhill. Pet. 47-48. In particular, EMC

argues that one with ordinary skill in the art would have found it obvious to add an additional remote backup file server or servers to Woodhill's system for additional data security, *e.g.*, in the event that the single remote backup file server was destroyed along with the local computer that backs up a binary object. *Id.* at 47 (citing to Ex. 1009, ¶ 29). EMC also provides an articulated reason with a rational underpinning to justify the legal conclusion of obviousness. *Id.* at 47-48. PersonalWeb does not challenge EMC's assertion that Woodhill teaches the claimed subject matter recited in independent claims 36 and 38.

The explanations provided by EMC with respect to how Woodhill teaches the claimed subject matter recited in independent claims 36 and 38 have merit and are otherwise unrebutted. Therefore, based on the record before us, we conclude that there is a reasonable likelihood that EMC will prevail on its assertion that independent claims 36 and 38 of the '280 patent are unpatentable over Woodhill. We authorize an *inter partes* review on this ground of unpatentability as well.

*B. Remaining Grounds of Unpatentability*

*Claims 36 and 38*

EMC contends that independent claims 36 and 38 are unpatentable under 35 U.S.C. §§ 102 and 103 based in whole or in part on Browne, Langer, ESM Manual, Satyanarayanan, or Kantor. Pet. 28-39 and 48-59. Those grounds of unpatentability are redundant to the grounds of unpatentability on which we initiate an inter parties review. Accordingly, we do not authorize an *inter partes* review on the remaining grounds of

unpatentability asserted by EMC against independent claims 36 and 38 of the '280 patent. *See* 37 C.F.R. § 42.108(a).

#### IV. ORDER

It is **ORDERED** that pursuant to 35 U.S.C. § 314(a), an *inter partes* review is hereby instituted as to claims 36 and 38 of the '280 patent for the following grounds of unpatentability:

A. Claims 36 and 38 as anticipated under U.S.C. § 102(e) by Woodhill.

B. Claims 36 and 38 as unpatentable under 35 U.S.C. § 103(a) over Woodhill.

It is **FURTHERED ORDERED** that pursuant to 35 U.S.C. § 314(c) and 37 C.F.R. § 42.4, notice is hereby given of the institution of a trial. The trial will commence on the entry date of this decision.

It is **FURTHER ORDERED** that an initial conference call with the Board is scheduled for 2 PM Eastern Time on June 3, 2013. The parties are directed to the Office Trial Practice Guide, 77 *Fed. Reg.* 48756, 48765-66 (Aug. 14, 2012) for guidance in preparing for the initial conference call, and should come prepared to discuss any proposed changes to the Scheduling Order entered herewith and any motions the parties anticipate filing during the trial.

Case IPR2013-00083  
U.S. Patent No. 6,415,280

For PETITIONER:

Peter Dichiara  
David L. Cavanaugh  
WILMER CUTLER PICKERING HALE AND DORR LLP  
[Peter.Dichiara@wilmerhale.com](mailto:Peter.Dichiara@wilmerhale.com)  
[David.Cavanaugh@wilmerhale.com](mailto:David.Cavanaugh@wilmerhale.com)

For PATENT OWNER

Joseph A. Rhoa  
Updeep S. Gill  
NIXON & VANDERHYE P.C.  
[jar@nixonvan.com](mailto:jar@nixonvan.com)  
[usg@nixonvan.com](mailto:usg@nixonvan.com)

alw