

UNITED STATES PATENT AND TRADEMARK OFFICE

BEFORE THE PATENT TRIAL AND APPEAL BOARD

SENSIO, INC.
Petitioner,

v.

SELECT BRANDS, INC.
Patent Owner.

Case IPR2013-00580
Patent D686,447

Before JOSIAH C. COCKS, THOMAS L. GIANNETTI, and
BENJAMIN D. M. WOOD, *Administrative Patent Judges*.

WOOD, *Administrative Patent Judge*.

FINAL WRITTEN DECISION
35 U.S.C. § 318(a) and 37 C.F.R. § 42.73

I. INTRODUCTION

A. *Background*

Sensio, Inc. (“Petitioner,” or “Sensio”) filed a Petition (Paper 2, “Pet.”) to institute an *inter partes* review of the sole claim of U.S. Design Patent No. D686,447 (Ex. 1001, “the ’447 patent”). On February 11, 2014, the Board instituted trial. Paper 6 (“Dec.”). Select Brands, Inc. (“Patent Owner,” or “Select Brands”) filed a Response (Paper 12, “PO Resp.”), to which Petitioner replied (Paper 17, “Pet. Reply”). By order dated August 8, 2014, we granted Patent Owner’s request to file a Sur-Reply to address issues related to the inventorship of the ’447 patent. Paper 19, 3. Patent Owner filed its Sur-Reply (Paper 20, “PO Sur-Reply”) on August 14, 2014. Oral hearing was held on September 30, 2014, and a transcript of the hearing (Paper 31, “Tr.”) is included in the record.

We have jurisdiction under 35 U.S.C. § 6(c). This Final Written Decision is entered pursuant to 35 U.S.C. § 318(a). For the reasons discussed below, we determine that Petitioner has met its burden to prove by a preponderance of the evidence that the sole claim of the ’447 patent is unpatentable.

B. *Related Proceedings*

Sensio indicates that the ’447 patent has been asserted in the following infringement action: *Select Brands, Inc. v. Sensio, Inc.*, No. 13-cv-2018 (KHV/GLR (D. Kan.). Pet. 1. Sensio also has petitioned for *inter partes* review of two patents related to the ’447 patent: U.S. Patent No. D669,731 (*Sensio, Inc. v. Select Brands, Inc.*, IPR2013-00500), and U.S. Patent No. D675,864 (*Sensio, Inc. v. Select Brands, Inc.*, IPR2013-00501).

C. The '447 Patent

The '447 patent, titled "Multiple Crock Buffet Server," issued on July 23, 2013 from an application filed December 14, 2012, and claims priority to January 13, 2011. Ex. 1024, cover page. The claim recites "[t]he ornamental design for a multiple crock buffet server, as shown and described." *Id.* Figures 1, 3, and 4 are representative of this design and are reproduced below:

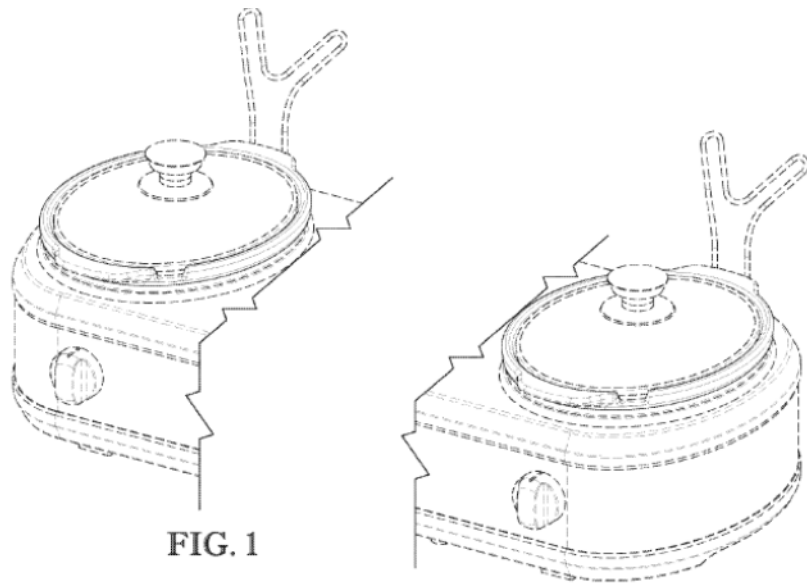
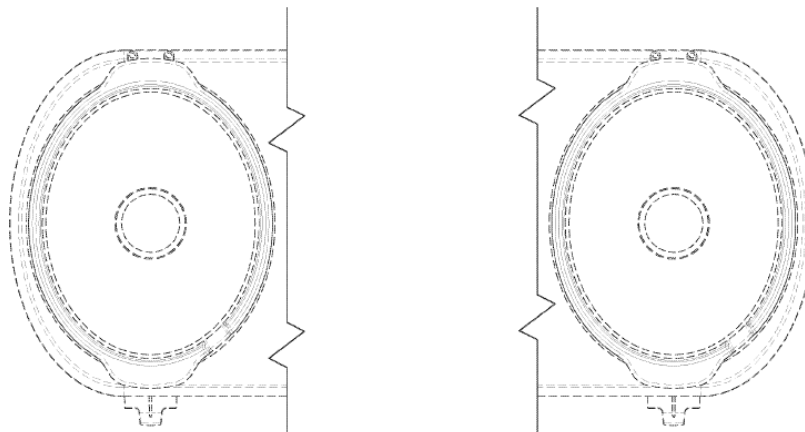
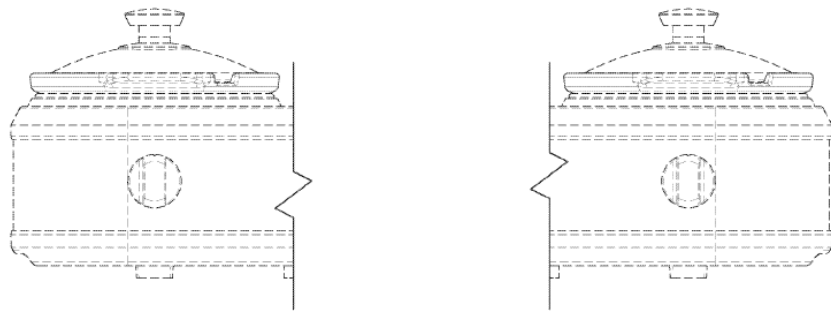

FIG. 1

'447 Patent, Fig. 1



'447 Patent, Fig. 3



'447 Patent, Fig. 4

Figures 1, 3, and 4 show front perspective, top plan, and front elevation views, respectively, of a multiple-crock buffet server with two oval server bowls. According to the description of Figure 1, the buffet server is depicted “as intermediately fragmented along its length so that the claimed design covers a buffet server with at least two oval server bowls variably spaced from one another.” Ex. 1024, cover page. The server housing, server control knobs, oval insert lids received by the bowls, oval liners that receive the bowls, and outer handle surfaces and radial groove on the rim of each bowl are shown in broken lines to indicate that they form no part of the claimed design. *Id.*

D. The Pending Grounds of Unpatentability

We instituted *inter partes* review of the '447 patent based on the following alleged grounds of unpatentability:

Anticipation by CN 101695429 A to Shi (Apr. 21, 2010) (“Shi '429”) (Ex. 1002);

Obviousness over Shi '429;

Anticipation by CN 301282889 (July 14, 2010) (“Shi '889”) (Ex. 1004);

Obviousness over Shi '889;

Anticipation by CN 301383763 (Nov. 17, 2010)
("Lu '763") (Ex. 1006);

Obviousness over Lu '763;

Anticipation by CN 301383762 (Nov. 27, 2010)
("Lu '762") (Ex. 1026); and

Obviousness over Lu '762.

Dec. 22.

II. ANALYSIS

A. *Claim Construction*

In the Decision on Institution, we stated that:

We construe the claim to be the ornamental design for a multiple-crock buffet server as depicted in solid lines in figures 1-7. In particular, the design is for a multiple-crock buffet server having at least two oval server bowls situated at adjacent ends along the length of the buffet server base housing, with the long axes of the oval server bowls parallel with each other and transverse to the length of the buffet server housing. The elements shown in broken lines do not form part of the claimed design.

Dec. 6. In its Response, Patent Owner states that "[f]or the purposes of this proceeding only, [it] accepts the Board's interpretation." PO Resp. 4.

Petitioner did not dispute this interpretation in its Reply. Having reviewed the parties' positions and the evidence adduced at trial, we see no reason to modify this construction, and therefore adopt it for purposes of this Final Decision.

B. Antedating the Prior Art

1. Background

a. Patent Owner's Contentions

Patent Owner does not dispute that each of Shi '429, Shi '889, Lu '763, and Lu '762 discloses the claimed design. *See generally* PO Resp. Instead, Patent Owner asserts that none of these references constitutes prior art under 35 U.S.C. § 102(a), as Petitioner alleges. *Id.* at 7–8. Shi '429 was published April 21, 2010, the earliest publication date of the three references at issue. Ex. 1003, 1; *see* Ex. 1005, 1 (Shi '889 published July 14, 2010); Ex. 1007, 1 (Lu '763 published November 17, 2010); Ex. 1027, 1 (Lu '762 published November 17, 2010). Patent Owner contends that the design claimed in the '447 patent was actually reduced to practice before April 21, 2010. *Id.* at 9–10. In support of this contention, Patent Owner provides the declarations of the three named inventors: William S. Endres, President of Patent Owner Select Brands (Ex. 2008); W. Eric Endres, Vice President of Marketing at Select Brands (Ex. 2009); and Mark T. Krasne, industrial designer at Select Brands (Ex. 2010) (collectively “Inventors”). *Id.*¹

The Inventors allege that Select Brands currently sells, under the brand name “TRU,” the model “BS-325” multiple-crock buffet server embodying the claimed design. Ex. 2008 ¶¶ 1, 5. The Inventors assert that the BS-325 product is made by Ningbo Wuji Electric Appliances Co., Ltd. (“Wuji”) in China for Select Brands, based on the Inventors’ design, which the Inventors “communicated” to Wuji. *Id.* ¶ 5, 6. The Inventors state that

¹ Because the inventor declarations are, in large part, identical, we will refer only to Ex. 2008, William Endres’s declaration, with the understanding that it represents the testimony of all three inventors.

“[b]ased upon the communicated design, Wuji produced prototypes . . . of the BS-325 Product to be reviewed and tested by Select Brands.” *Id.* ¶ 6. According to the Inventors, the first prototype was manufactured and sent to Select Brands in January 2010 (“the January 2010 Prototype”). *Id.* ¶¶ 6, 8. The Inventors testify that employees of Select Brands photographed the January 2010 Prototype when it was received in the United States on January 27, 2010, and that the photographs are in the record as Exhibit 2002. *Id.* ¶ 8. The Inventors allege that Wuji subsequently produced three other prototypes, each having the same design, photographs of which are in the record as Exhibits 2005, 2006, and 2007, respectively. *Id.* ¶¶ 15–25. Patent Owner states that all of the prototypes “were disposed of by Select Brands in the ordinary course of business” prior to this proceeding. Ex. 1028, 2. Thus, Exhibits 2002, 2005, 2006, and 2007 are the only evidence of the appearance of these prototypes. According to Patent Owner, the “design features remained unchanged from the January 2010 [Prototype] to the present day commercial model [BS-325].” PO Resp. 9; *see* Ex. 2008 ¶¶ 8–10 (same).

Patent Owner contends that “the pre-April 21, 2010 reduction to practice” is corroborated by several of its business records. PO Resp. 19–26. Patent Owner first refers to the “‘Select Brands Incorporated Product Specification’ (the ‘Product Specification’), dated February 23, 2010.” *Id.* at 19 (citing Exs. 2003, 2008-2010 ¶¶ 11–12). According to Patent Owner, a photograph of the January 2010 Prototype is reproduced on the Product Specification’s cover page. *Id.* at 19–20. Patent Owner next refers to a “record called ‘TRU Lid Rest Concept BS-325’ (the ‘Concept Document’), dated February 16, 2010.” *Id.* at 21 (citing Exs. 2004; 2008-2010 ¶¶ 13–14). Patent Owner states that “[t]he slow cooker design depicted by the Concept

Document was prepared to show how the previously developed slow cooker design, embodied by the [January 2010] Prototype shown in Exhibit 2002, could be modified by the addition of the lid rests.” *Id.* at 21–22.

Patent Owner further relies on a document titled “Corrective Action Plan for TRU Three 2.5 Qt Oval Buffet Station BS-325” (the “CAP Document”) dated April 2, 2010. *Id.* at 23–24; Ex. 2006. According to Patent Owner, the CAP Document contains photographs of one of the prototypes received by Select Brands prior to April 26, 2010. *Id.* at 24. Finally, Patent Owner refers to a document titled “Intertek Listing Constructional Data Report” (the “Listing Report”) dated April 6, 2010. *Id.* at 25. Patent Owner states that the Listing Report contains photographs of another prototype that was independently tested to ensure compliance with North American safety standards. *Id.* at 26.

b. Petitioner’s Reply

Petitioner responds that because Wuji, not the named Inventors, made the BS-325 prototypes, the prototypes do not constitute a reduction to practice by the named Inventors and do not support the Inventors’ claim to an earlier invention date. Pet. Reply 4. Petitioner further asserts that Patent Owner has not argued, much less established, that the Wuji-built prototypes inure to the Inventors’ benefit. Petitioner contends that “[t]he first requirement of inurement is that the ‘inventor must have conceived of the invention,’” and Patent Owner has not established that the named Inventors conceived the claimed design. *Id.* at 4 (citing *Genentech, Inc. v. Chiron Corp.*, 220 F.3d 1345, 1354 (Fed. Cir. 2000); *Cooper v. Goldfarb*, 240 F.3d 1378, 1383 (Fed. Cir. 2001) (“*Cooper II*”). Finally, Petitioner contends that the photographs of the various prototypes are insufficient to show that they

embody the claimed design. *Id.* at 10. Petitioner supports this contention with the declaration of Lance Rake, Professor of Industrial Design at Kansas University. *Id.* at 11–15; Ex. 1024. Relying on Prof. Rake’s testimony, Petitioner asserts that “it would be impossible for a designer of ordinary skill to determine from the views [of the January 2010 Prototype] if the pots from this prototype are round, elliptical or oval, or another continuously curved shape.” *Id.* at 12 (citing Ex. 1024 ¶ 28). Petitioner and Prof. Rake contend that the photographs of the other prototypes are similarly deficient. *Id.* at 13 (citing Ex. 1024 ¶¶ 45–50, 53–56, 59–64).

c. Patent Owner’s Sur-Reply

In its Sur-Reply, Patent Owner disputes that it was required to show that it conceived the claimed design in order for the Wuji-built prototypes to inure to its benefit. Patent Owner argues that because it has “demonstrate[d] actual reduction to practice before [Shi ’429’s publication date], conception is irrelevant.” PO Sur-Reply 1. Patent Owner asserts that the cases on which Petitioner relies, *Cooper II* and *Genentech*, are not applicable because they concern the reduction to practice of utility patents rather than design patents, and specifically “whether recognition of utility by another, that was not communicated to the inventor, could inure to the benefit of the inventor.” *Id.*

Patent Owner further argues that Wuji’s prototypes inure to its benefit because “acts by others working explicitly or implicitly at the inventor’s request will inure to [the inventor’s] benefit.” *Id.* at 2–3 (citing *Cooper v. Goldfarb*, 154 F.3d 1321, 1332 (Fed. Cir. 1998) (“*Cooper I*”); *Applegate v. Scherer*, 332 F.2d 571, 573 (CCPA 1964)). According to Patent Owner, “[a]n agency relationship (whether express or not) between the inventor and

a supplier who acts at the suggestion or request of the inventor will result in the supplier's work inuring to the inventor.” *Id.* at 3. Patent Owner asserts that Wuji acted at Select Brand's “suggestion or request,” as shown by the Product Specification and the CAP Document. *Id.* at 3–4. Patent Owner contends, in the alternative, that if it is required to show that it conceived the claimed design as part of its inurement case, the evidence is sufficient to do so. *Id.* at 4–5. Patent Owner primarily relies on the testimony from each inventor that they “designed the BS-325 Product and communicated the design of the BS-325 Product to Wuji.” *Id.* at 5 (citing Exs. 2008–2010 ¶¶ 6). Patent Owner also relies on the inventor declarations submitted during the prosecution of the '447 patent. *Id.* (citing Ex. 1001, 1). Patent Owner contends that the Inventors' testimony is corroborated by the evidence of record that shows that “Wuji acted in all respects of the project at Select's direction.” *Id.*

2. Discussion

Petitioner bears the burden of persuasion, by a preponderance of the evidence, that the challenged claim is unpatentable. 35 U.S.C. § 316(e). Petitioner has proffered references that presumptively constitute prior art under 35 U.S.C. § 102(a) because they were published before the '447 patent's January 13, 2011 priority date, giving rise to Patent Owner's burden to produce evidence supporting a date of invention before the earliest reference publication date, in this case April 21, 2010. *Mahurkar v. C.R. Bard, Inc.*, 79 F.3d 1572, 1576–77 (Fed. Cir. 1996).

The standard of inventorship required for utility patents applies equally to design patents. *Hoop v. Hoop*, 279 F.3d 1004, 1007 (Fed. Cir. 2002). “To antedate . . . an invention, a party must show either an earlier

reduction to practice, or an earlier conception followed by a diligent reduction to practice.” *Purdue Pharma L.P. v. Boehringer Ingelheim GMBH*, 237 F.3d 1359, 1365 (Fed. Cir. 2001) (internal citation omitted). Patent Owner’s position is based on the first of these options, i.e., that it was the first to reduce the invention to practice, rather than the first to conceive plus diligent reduction to practice. PO Resp. 7–8; PO Sur-Reply 1.

Reduction to practice of a design “requires the production of an article embodying that design.” *Fitzgerald v. Arbib*, 268 F.2d 763, 765 (CCPA 1959). Here, it is undisputed that Wuji, rather than Patent Owner, made the BS-325 prototypes on which Patent Owner relies to establish actual reduction to practice. Assuming, without deciding, that the prototypes embody the claimed design, the issue is whether the Wuji-built prototypes inure to Patent Owner’s benefit. We hold that they do not.

First, contrary to Patent Owner’s position, we do not believe that conception is “irrelevant” to the inurement analysis. On the contrary, we agree with Petitioner that under *Genentech* and *Cooper II*, Patent Owner must show that it conceived the design and communicated the design to Wuji in order for the prototypes to inure to Patent Owner’s benefit.² For example, in *Genentech*, in the context of deciding whether a non-inventor’s recognition of the utility of a reduction to practice inured to the inventor’s benefit, the Federal Circuit held that the inventor must first show that it conceived the invention. *Genentech*, 220 F.3d at 1354. Patent Owner

² *See also Hoop*, 279 F.3d at 1007 (in a design-patent interference case, holding that the “person or persons who *conceived* the patented [design] . . . may then use the services, ideas, and aid of others in the process of perfecting his invention without losing his right to a patent” (emphasis added)).

argues that *Genentech* and *Cooper II* should be limited to this narrow context, such that only “inurement of the recognition of utility require[s] corroboration of earlier conception by the inventor.” PO Sur-Reply 1. We disagree. In *Cooper II*, the court applied “a modified version of the *Genentech* test” to a different issue, requiring a party to show that it conceived the invention to obtain the benefit of another party’s knowledge that a tested material met the limitation of the interference count. *Cooper II*, 240 F.3d at 1385. *Cooper II* demonstrates the Federal Circuit’s view that conception must be shown whenever a party seeks the benefit of another party’s reduction to practice.³ This requirement makes sense: otherwise, a party could establish that it is the first inventor without showing either that it was the first to conceive or the first to reduce to practice, contrary to the requirements for antedating an invention set forth in, e.g., *Purdue Pharma, supra*.

The cases on which Patent Owner relies, *Cooper I* and *Applegate*, are not to the contrary. In neither case did the court apply the inurement

³ At oral hearing Patent Owner’s counsel argued that *Genentech* and *Cooper II* are distinguishable because “they both arise in the context of an interference proceeding . . . in which [the competing inventors] already have an obligation to submit and corroborate conception dates because that’s the very nature of the interference proceeding.” Tr. 12:11–15. Thus, counsel argues, Petitioner is “conflating some requirements that will always exist in interference with what’s required to show inurement in the context of simply attempting to antedate a prior art reference.” *Id.* at 12:17–19. But parties to an interference do not automatically have to contest which inventor was the first to conceive, because priority can be awarded to the first to reduce the invention to practice. *Price*, 988 F.2d 1190. In any event, both decisions required a showing of conception as a prerequisite to a finding of inurement, and not simply because the parties were engaged in an interference. *Genentech*, 220 F.3d at 1354; *Cooper II*, 240 F.3d at 1385.

doctrine to the benefit of a party that did not first conceive the invention at issue. *See Cooper I*, 154 F.3d at 1326–27 (noting the Board’s determination that Cooper—the party to whom the acts of another might inure—was the first to conceive the invention); *Applegate*, 332 F.2d at 573 (affirming the Board’s determination that Scherer—the party to whom Applegate’s reduction to practice inured—was the first to conceive the invention). Thus, these cases cannot support Patent Owner’s argument that the inurement doctrine does not require a showing of conception.

Second, we are not persuaded that Patent Owner produced sufficient evidence to show that it conceived the claimed design prior to April 21, 2010. Patent Owner points us to the inventors’ testimony that they “designed the BS-325 Product and communicated the design of the BS-325 Product to Wuji.” PO Sur-Reply 5. But “an inventor’s testimony, standing alone, is insufficient to prove conception—some form of corroboration must be shown.” *Price v. Symsek*, 988 F.2d 1187, 1194 (Fed. Cir. 1993) (internal citation omitted). The corroboration requirement “provides a bright line for . . . the PTO to follow in addressing the difficult issues relating to invention dates.” *Mahurkar*, 79 F.3d at 1577. In assessing corroboration, a “rule of reason analysis is applied,” in which “an evaluation of all pertinent evidence must be made so that a sound determination of the credibility of the inventor’s story may be reached.” *Id.* (internal quotation marks and citation omitted). However, “[t]he rule of reason . . . does not dispense with the requirement for some evidence of independent corroboration.” *Coleman v. Dines*, 754 F.2d 353, 360 (Fed. Cir. 1985). That independent corroboration is required means co-inventors cannot corroborate each other’s testimony.

Medichem, S.A. v. Roblabo, S.L., 437 F.3d 1157, 1170–71 (Fed. Cir. 2006) (internal citation omitted).

Patent Owner argues that “the evidence of record shows that Wuji acted in all respects of the project at Select’s direction, which corroborates the inventors’ testimony under the rule of reason.” PO Sur-Reply 5. We understand that the “evidence of record” to which Patent Owner refers includes the Product Specification, the Concept Document, the CAP Document, and the Listing Report. PO Resp. 23–30; PO Sur-Reply 4; Exs. 2003, 2004, 2006, 2007. We have reviewed these documents and are not persuaded that they corroborate the inventors’ testimony regarding conception. None of these business records addresses the claimed ornamental design, much less who conceived the design. Instead, they describe certain technical aspects of the BS-325 product (*see, e.g.*, Ex. 2003, 2–8); Patent Owner’s efforts to work with Wuji to bring the BS-325 product to market (*see, e.g.*, Ex. 2006); the design of a wire formed lid rest attachment that is not part of the claimed design (Ex. 2004); and the results of electrical safety testing (Ex. 2007). Moreover, the documents appear to have been created after Wuji produced the January 2010 Prototype, and, therefore, after the design already had been conceived and reduced to practice. Thus, while these documents may corroborate some aspects of the inventors’ testimony, they do not corroborate the statement on which Patent Owner relies, i.e., that the inventors conceived the BS-325’s ornamental design and communicated the design to Wuji before the product was first reduced to practice.

Further, we note the absence from the record of any evidence of communications between Patent Owner and Wuji in or before January 2010,

when the product was designed. Patent Owner has not provided any emails, letters, sketches, etc. that would have communicated the claimed design to Wuji before Wuji built the first prototype. Nor do we have any testimony, from the inventors or otherwise, that provides any specific information regarding Patent Owner's communications with Wuji before Wuji made the January 2010 Prototype.⁴ In *Woodland Trust v. Flowertree Nursery, Inc.*, 148 F.3d 1368 (1998), the Federal Circuit found significant "the absence of any physical record to support the oral evidence," despite the "the ubiquitous paper trail of virtually all commercial activity" that normally exists "in modern times." *Id.* at 1373. As discussed above, the business records on which Patent Owner relies do not make up for the absence of such evidence.

In summary, having reviewed Patent Owner's evidence as a whole, we are not persuaded that the inventor's testimony is corroborated adequately, and we determine that Patent Owner has not met its burden of producing evidence that it invented the patented design prior to April 21, 2010. Accordingly, we agree with Petitioner that Shi '429, Shi '889, Lu '763, and Lu '762 are prior art under 35 U.S.C. § 102(a).

⁴ At the oral hearing Patent Owner's counsel stated that Patent Owner mostly corresponded with Wuji via email, but that "[t]here was a crash in [Patent Owner's] system" that prevented Patent Owner from finding its email correspondence. Tr. 30:3–10. Patent Owner's counsel also stated that he believed that sketches of the design were made before the prototypes were manufactured, but that Patent Owner has been unable to find them. *Id.* at 30:11–14. Nonetheless, Patent Owner's counsel also stated that "documentary evidence dated prior to the first prototype" does exist, but that "we didn't view we had to corroborate conception under the standards as we understand them." *Id.* at 10:15–25.

C. The '447 Patent Claim is Unpatentable

In instituting trial, we determined that there was a reasonable likelihood that the claim of the '447 patent was anticipated by, and would have been obvious over, each of Shi '429, Shi '889, Lu '763, and Lu '762. Dec. 7–16. As stated above, Patent Owner does not dispute this determination beyond arguing that these references are not prior art. Upon review of the claim of the '447 patent, as well as each of Shi '429, Shi '889, Lu '763, and Lu '762, we determine that Petitioner has shown by a preponderance of the evidence that each of Shi '429, Shi '889, Lu '763, and Lu '762 anticipates the claim of the '731 patent under 35 U.S.C. § 102. *See* Dec. 7–19 (discussing the ordinary-observer test for anticipation of a design patent, and comparing the patented design with the designs depicted in each of each of Shi '429, Shi '889, Lu '763, and Lu '76263 in light of that test). We further determine that the preponderance of the evidence of record supports the determination that each of Shi '429, Shi '889, Lu '763, and Lu '762 renders the claim of the '731 patent unpatentable under 35 U.S.C. § 103. *See* Dec. 11–12, 14, 17, 20 (discussing the test for determining obviousness of a design patent, and comparing the patented design with the designs depicted in each of each of Shi '429, Shi '889, Lu '763, and Lu '762 in light of that test).

D. Patent Owner's Motion to Exclude Evidence

Patent Owner asks that we exclude: (1) Ex. 1021, a document in Chinese that Petitioner alleges shows that Junda Shi, the named inventor on two of the asserted references, is the legal representative of the Chinese company that manufactures the commercial embodiments of the patented design; (2) Ex. 1022, the English-language translation of Ex. 1021; and (3)

Ex. 1024, the expert declaration of Professor Lance Rake. Paper 22, 1. We do not rely on the disputed evidence in rendering our Decision. Therefore, Patent Owner's Motion to Exclude is dismissed as moot.

III. CONCLUSION

We conclude that Petitioner has demonstrated by a preponderance of the evidence that the sole claim of the '447 patent is anticipated by, and would have been obvious over, each of Shi '429, Shi '889, Lu '763, and Lu '762.

IV. ORDER

For the reasons given, it is

ORDERED that the sole claim of the '447 patent has been shown by a preponderance of the evidence to be unpatentable under 35 U.S.C. §§ 102 and 103; and

FURTHER ORDERED that Patent Owner's Motion to Exclude is *dismissed*.

This is a final decision. Parties to the proceeding seeking judicial review of the decision must comply with the notice and service requirements of 37 C.F.R. § 90.2.

IPR2013-00580
Patent D686,447

PETITIONER:

Kathleen A. Daley

Elizabeth D. Ferrill

FINNEGAN, HENDERSON, FARABOW, GARRETT & DUNNER, L.L.P.

kathleen.daley@finnegan.com

elizabeth.ferrill@finnegan.com

PATENT OWNER:

Scott R. Brown

Jennifer C. Bailey

HOVEY WILLIAMS LLP

jcrawford@hoveywilliams.com